

Installation Instructions

CS Jamb Kit™

CS Cavity Sliders Pocket Door Jamb Kit

Before You Start

Please ensure your purchased product is compatible with the CS Jamb Kit™. The CS Jamb Kit™ is designed for use with a single, 4" Framing (2x4) CS Cavity Slider® Pocket Door Frame that meets the specifications in the table below.

If your door is smaller than the listed sizes, refer to the parts list for the necessary formula to cut the head jambs, split jambs, and closing jamb to size.

Door Size	Jamb Size	Door Thickness
3'0"x8'0"	4-9/16"	1-3/8"
		1-3/4"
	4-7/8"	1-3/8"
		1-3/4"
4'0"x8'0"	4-9/16"	1-3/4"
	4-7/8"	1-3/4"

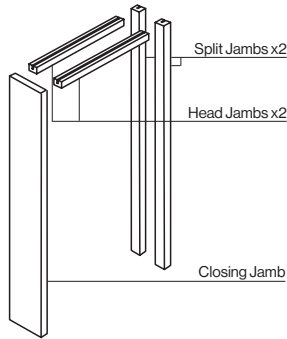

DW = Door Width **DH** = Door Height

If cutting the Closing Jamb **C** ensure you do **not** cut the **pre-drilled end**.

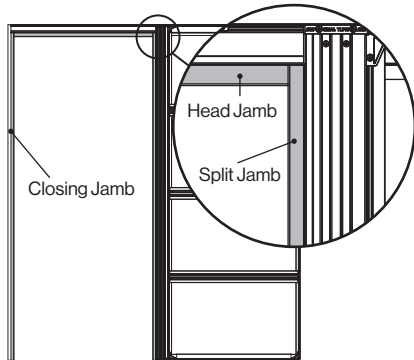

NOTE: When cutting the jamb kit down, the split jamb trim is installed **FIRST** before the head jamb.

The split jamb trim should extend the full jamb height. Be sure to adjust the head jamb length to account for this.

Parts List

A	Head Jamb x2	DW - 3/4" (DW - 19mm)
B	Split Jamb x2	DH + 1-11/16" (DH + 42.9 mm)
C	Closing Jamb	DH + 3-11/16" (DH + 93.7mm)
D	Additional Parts	#6 x 1-1/4" (31.75mm) wood screws for attaching closing jamb to frame x2

These installation instructions begin during the **trim and finishing stage** of the CS Cavity Slider® Pocket Door Frame instructions.

Please scan the following QR code or visit CavitySliders.com to download the full installation instructions.



Attaching the Closing Jamb and Installing the Pocket Frame

1. Locate the pre-drilled holes at the top of the Closing Jamb **C** that align with the CS Track. Secure the Closing Jamb in place with the two screws provided **D**.

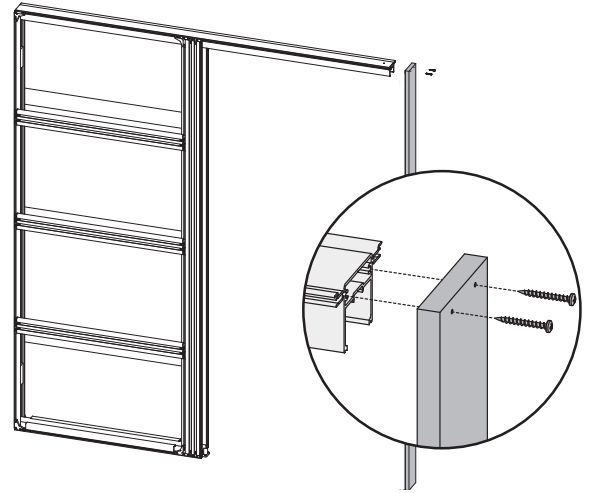

2. Position the pocket frame into the rough opening, using a level to ensure it is properly aligned. Secure the pocket frame by fastening it through the Back Stud, Bottom Plate and Closing Jamb.

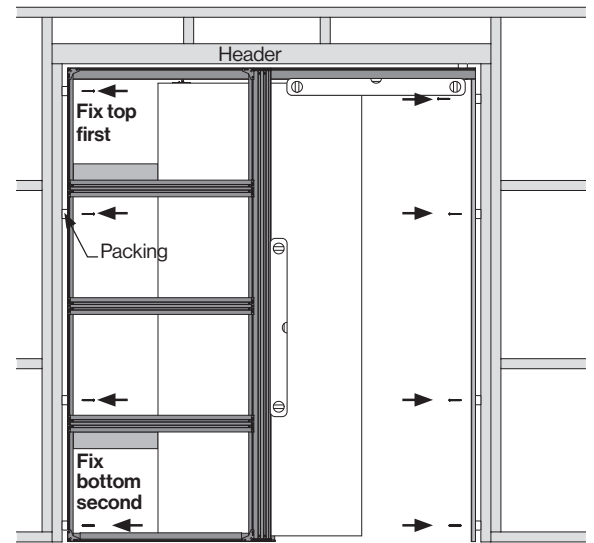

Attaching the Trim Clips

3. Using a rubber mallet, install the 16 CS Trim Clips into the grooved channels of the supplied Head Jambs **A** and Split Jambs **B**.

Evenly distribute the clips as follows: Three (3) Trim Clips in each Head Jamb and Five (5) Trim Clips in each Split Jamb.

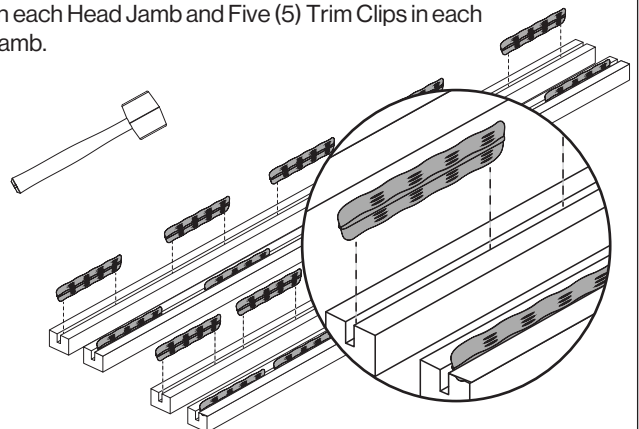

Attaching the Split Jambs and Installing the Door

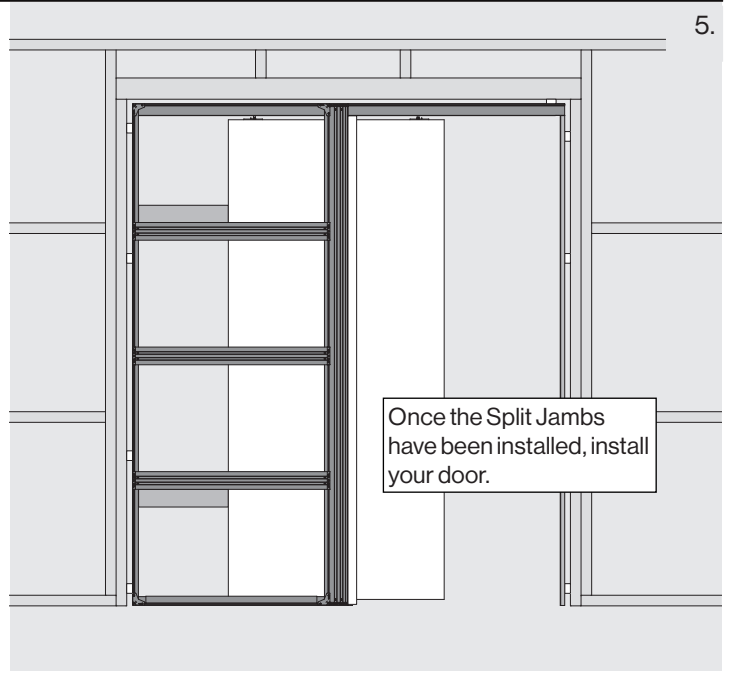
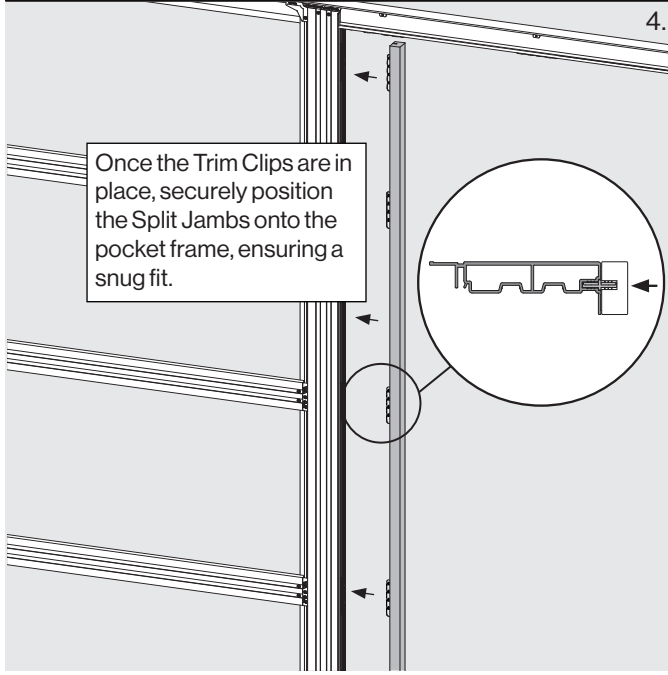

Attaching the Head Jambs

